

ZIPBOLT™ UT-RAILBOLT

TOP VIEW BOTTOM VIEW SIDE VIEW

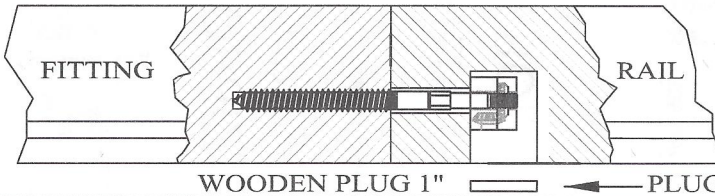

GEARHEAD

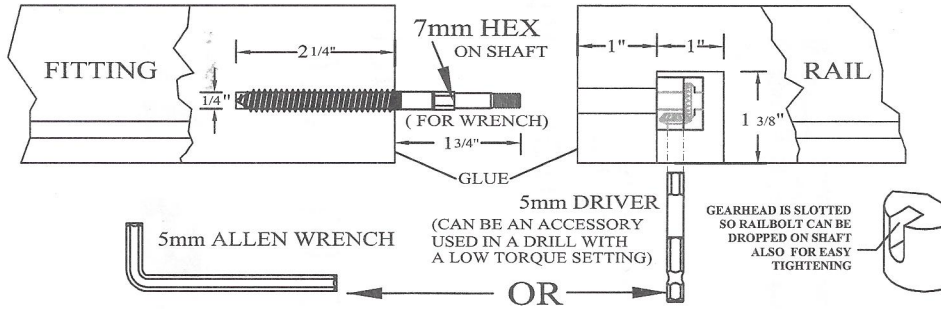

A TEMPLATE FOR JOINING RAIL TO FITTING USING RAIL CUTOFF

1. PREPARING A TEMPLATE
MAKE A TEMPLATE BY CUTTING A 3/16" WAFFER FROM THE APPROPRIATE HAND RAIL. MEASURE ON THE CENTERLINE 15/16" FROM THE BOTTOM OF THE RAIL. DRILL A 1/16" DIA. HOLE AS SHOWN IN FIGURE 1.

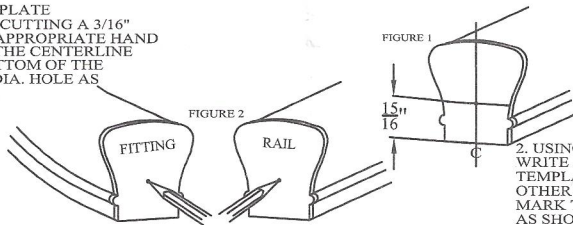

2. USING THE TEMPLATE
WRITE RAIL ON ONE SIDE OF THE TEMPLATE AND FITTING ON THE OTHER SIDE. ALIGN THE TEMPLATE. MARK THE RAIL AND FITTING AS SHOWN IN FIGURE 2.

DRILLING RAIL AND FITTING - JOINING WITH RAIL BOLT ASSEMBLY - INSTALLING HOLE PLUG

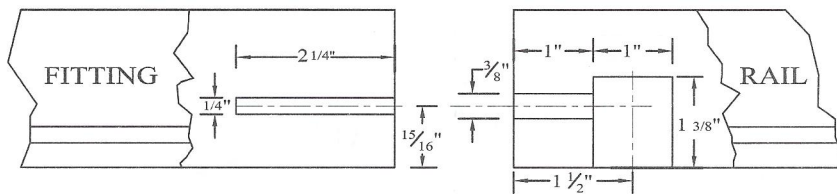

- DRILL 1/4" DIA. HOLE IN FITTING 2 1/8" DEEP IN LOCATION MARKED BY TEMPLATE (SEE FIG. 2)
- DRILL A 1" DIA. HOLE IN BOTTOM OF RAIL ON CENTERLINE, 1-1/2" FROM END OR RAIL. HOLE SHOULD BE 1-3/8" DEEP.
- USING MARK MADE WITH TEMPLATE (SEE FIG. 2) DRILL A 3/8" DIA. HOLE IN END OF RAIL. HOLE SHOULD BE 1-1/2" DEEP.
- INSTALL RAIL BOLT IN FITTING WITH 1-7/8" OF BOLT PROTRUDING.
- ASSEMBLE RAIL AND FITTING DRY TO CHECK FIT USING 7mm DRIVER ACCESSORY OR ALLEN WRENCH. USE GLUE ON FINAL ASSEMBLY. APPLY GLUE TO EDGES OF PLUG AND COVER 1" DIA. HOLE IN BOTTOM OF RAIL. SAND SMOOTH.

OR YOU CAN USE TEMPLATE ON OTHER SIDE